

Mark 978 Series

Sanitary Control Valves - JD Version

The Mark 978-JD (Jorlon Diaphragm) Series is designed to meet the rigid specifications for sterile process and clean utility control valves. This valve series is suitable for a wide variety of applications in the, bio-pharmaceutical, Parenteral, cosmetic, dairy and food and beverage industries.

The Mark 978 meets ASME BPE 2014 guidelines, and is ideally suited for a wide range of flowing media in both the clean utility and process areas of sanitary and aseptic systems.

High rangeability, true characterized trim, high capacities, superior temperature and pressure ratings, facilitated by a superior diaphragm, make the MK978 the sanitary control valve for sterile process, buffer, WFI and acid metering, and clean gas and steam services.

Whether the need is to control pressure, temperature, flow, pH, or another variable, the MK978 is the right valve for your process.

FEATURES

- Specialized design of diaphragm seal and components allows ultra-high cycle life and lifetime diaphragm warranty
- Jorlon diaphragm – highest continuous steam pressure ratings on the market, full CIP/SIP capabilities
- FDA & USP Class VI compliance standard on all process seal and seat materials
- Self draining – Angle Body: when mounted in vertical (all sizes) or horizontal orientations (except 3"); IN-LINE: 1", 1-1/2" & 2" when mounted in horizontal line E bodies are NOT self-draining.
- No guiding in the wetted area – prevents particulate generation
- Mechanically polished internal components – 20Ra (0,5 µm) finish, electropolish – standard; , 8Ra optional.
- Wetted parts made of 100% ASTM A479 316L Stainless Steel barstock
- Maintenance-friendly – easy to perform sanitary maintenance with simple disassembly and reassembly
- Steel, baked corrosion resistant coated multi-spring actuators to meet a wide range of differential pressure requirements while providing excellent corrosion resistance during washdown

CRN Registration Number Available

Important design changes for 1/2" - 1": New: orientation for gravity draining, and Bi-directional flow capability



AVAILABLE FINISHES

Body

- Standard: 20 Ra mechanical finish on internal wetted surfaces (0,5 µm); machine finish on exterior (63 RMS), and electropolished inside and out
- Optional: 20 Ra mechanical finish on external surfaces (0,5 µm); 8 Ra finish on internal or external surfaces (0,2 µm)

Stem

- Standard: 20 Ra mechanical finish and electropolish (0,5 µm)
- Optional: 8 Ra mechanical finish (0,2 µm)

APPLICATIONS

A wide variety of applications exist for the MK978 in the pharmaceutical, biotech, health care, and food & beverage and other industries including:

Processes

- Fermenter
- Bioreactor
- Lyophilization
- Chromatography
- SIP/CIP Systems
- Parenteral filling

Media

- Bio-process
- Caustic
- Acids
- Buffer
- Clean Steam
- WFI

SPECIFICATIONS – JORLON DIAPHRAGM

Sizes

- Angle Body: 1/2" (DN15) through 3" (DN80)
- InLine Series: 1" (DN25) through 2" (DN50)

Body/Bonnet Connection: bolted flange

Body/Bonnet Seal: valve diaphragm serves as body/ bonnet seal

Body Material: ASTM A479 316L SST Barstock

Stem Material: ASTM A479 316L SST Barstock

Bonnet Material: ASTM A479 316L SST Barstock

Diaphragm

Jorlon (1/2" – 3")

- FDA/USP Class VI to +340°F (171°C)

Stem Bushing: FDA PEEK (no process contact)

Actuators

Pneumatic

- 1/2" – 1" (DN15 – DN25); 35M & 55M: Steel, baked corrosion resistant coating
- 1-1/2" – 2" (DN40 – DN50); 55M & 85M: Steel, baked corrosion resistant coating
- 3" (DN80); 85M: Steel, baked corrosion resistant coating

Soft Seat Option (Cv ≥ 3.5 only)

- PTFE FDA/USP Class VI to 252°F (122°C) continuous or 275°F (135°C) in intermittent (<15 min over 1 hour)
- PEEK FDA/USP Class VI to 350°F (177°C)

Electric

- Contact factory

Shutoff

- Standard: ANSI Class III with metal seat
- Optional: ANSI Class VI with soft seat (Cv > 3.5 only)

Ranges: 3-15, 6-30, 3-9*, or 9-15* psi (0,2-1,0; 04-2,0; 0,2-0,6; or 0,6-1,0 bar) (* positioner required); –

Maximum Pressure @ 100°F (38°C)

- Jorlon (1/2" – 3"): 150 psi (10,3 bar)

Maximum Pressure/Temperature Rating

- Jorlon (1/2" – 3"): 100 psi @ +340°F (6,9 bar @ +171°C)

Flow Characteristics: Linear, equal percentage, or quick opening (consult factory for quick opening's Cvs)

Cv (Kv) Ratings (Diaphragm)

Cv (Kv) Ratings		
Size	Linear	Equal Percentage
1/2"	0.2 / 0.5 / 1.0 (0,17 / 0,43 / 0,86)	
3/4"	1.0 \ 2.0 \ 3.5 \ 5.0 (0,86 \ 1,72 \ 3,01 \ 4,30)	
1"	3.5 \ 5.0 (3,01 \ 4,30)	
	7.5 \ 15 (6,45 \ 12,90)	7.5 (6,45)
1-1/2"	5.0 \ 10 \ 15 \ 20.0 (4,30 \ 8,60 \ 12,90 \ 17,20)	
	30 (25,80)	
2"	10 \ 15 \ 20 \ 30 (8,60 \ 12,90 \ 17,20 \ 25,8)	
	40, 60, 70* (34,4 \ 52 \ 60,55*)	
3"	75\100 (65\86)	60\80\90 (52\69\77)

* Modified Linear - Contact factory for more information

Rangeability: Control valve rangeability is a function of installation piping, media properties, flow and differential pressure. For information regarding rangeability for your application, please contact your representative or the factory with installation and application information.

MAXIMUM Δ Ratings, PSI (BAR)

Valve Size	Valve Cv	Actuator Size	ATO 3-15	ATO 6-30 or with positioner @ 40 psi	ATC 3-15 or with positioner @ 20 psi	ATC 6-30 @ 40 psi
1/2"	0.2 / 0.5 / 1.0	35M/55M	150 (10,3)	150 (10,3)	150 (10,3)	150 (10,3)
3/4"	1 / 2 / 3.5 / 5	35M/55M	150 (10,3)	150 (10,3)	150 (10,3)	150 (10,3)
1"	3.5 / 5	35M	150 (10,3)	150 (10,3)	150 (10,3)	150 (10,3)
1"	3.5 / 5	55M	150 (10,3)	150 (10,3)	150 (10,3)	150 (10,3)
1"	7.5 / 15	35M	75 (5,2)	120 (8,3)	75 (5,2)	150 (10,3)
1"	7.5 / 15	55M	150 (10,3)	150 (10,3)	150 (10,3)	150 (10,3)
1-1/2"	5 / 10 / 15	55M	N/A	126 (8,7)	150 (10,3)	150 (10,3)
1-1/2"	5 / 10 / 15	85M	N/A	150 (10,3)	150 (10,3)	150 (10,3)
1-1/2"	20 / 30	55M	N/A	97 (6,7)	150 (10,3)	150 (10,3)
1-1/2"	20 / 30	85M	N/A	150 (10,3)	150 (10,3)	150 (10,3)
2"	10/15/20/30/40/60	55M	N/A	34 (2,3)	111 (7,7)	111 (7,7)
2"	10/15/20/30/40/60	85M	N/A	111 (7,7)	150 (10,3)	150 (10,3)
3"	60/75/80/90/100	85M	N/A	100 (6,9)	100 (6,9)	100 (6,9)

Note: 1-1/2", 2" & 3" require positioner supplied by Steriflow or customer. 3" actuator is bench set @ 11 - 30 psi

* 1/2" - 1" may be sold with I/P instead of positioners

** 1/2" – 2" with positioner ATO actuator is bench set @ 6-30 psi/ ATC actuator is bench set @ 3-15 psi.

MARK 978E JORLON DIAPHRAGM SEAL (1/2" - 1" ANGLE STYLE)

NEW Bi-direction flow capability.

Valve can be installed with inlet on side or bottom. Self draining when valve is installed with inlet on side and valve in upright position as shown.

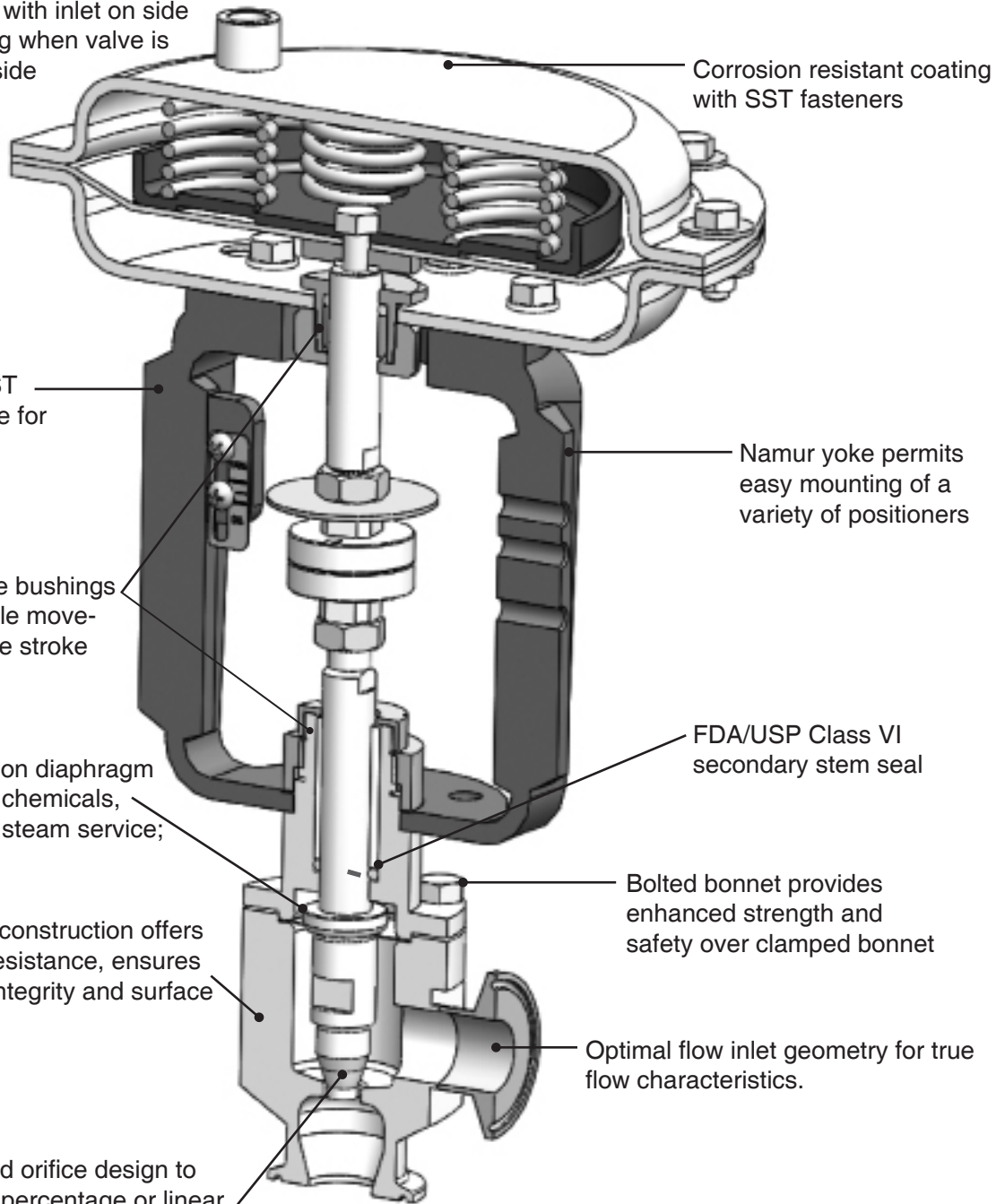

SPECIFICATION

Stainless steel sanitary control valve shall be made from ASTM A479 316L barstock material, which includes body and all wetted metal parts. Control valve with the stem sealed by FDA approved and USP Class VI certified Jorlon diaphragm with lifetime warranty. The valve stem shall be supported by a one piece, SS NAMUR Yoke with two extended PEEK™ Guide bushings to provide structural rigidity and true guiding in any installation orientation. Guiding of valve stem/plug shall be outside of the wetted process areas of valve above diaphragm. Control valve shall have secondary stem seal, and extended guide bushing to provide additional support for multiple installation orientations. Valve shall be self draining in at least one orientation.

JORLON DIAPHRAGM SEAL (1-1/2" – 2" ANGLE STYLE)

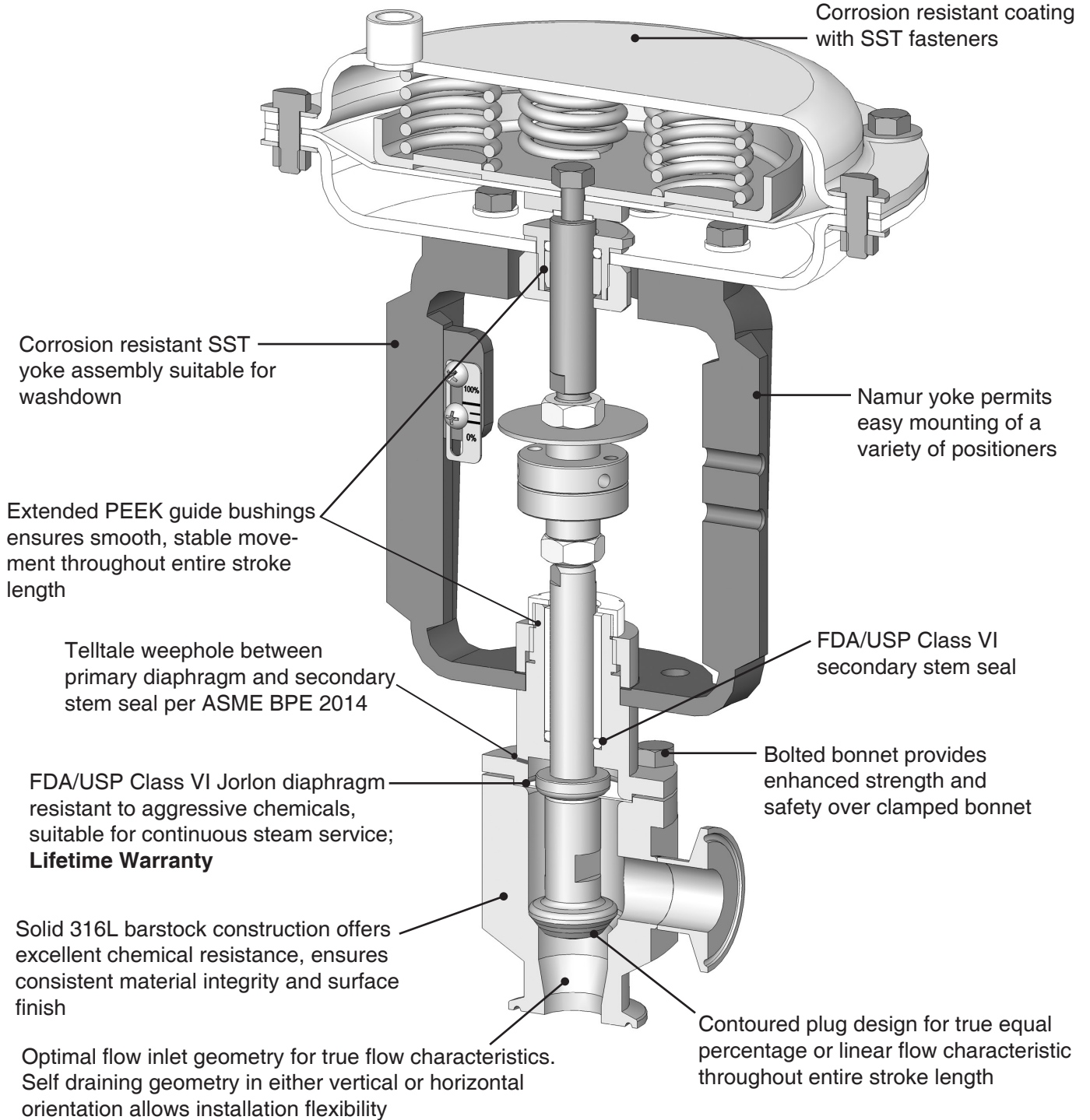

SPECIFICATION

Stainless steel sanitary control valve shall be made from ASTM A479 316L barstock material, which includes body and all wetted metal parts. Control valve with the stem sealed by FDA approved and USP Class VI certified Jorlon diaphragm with lifetime warranty. The valve stem shall be supported by a one piece, SS NAMUR Yoke to provide structural rigidity in any installation orientation. Guiding of valve stem/plug shall be outside of the wetted process areas of valve above diaphragm. Control valve shall have secondary stem seal, and extended guide bushing to provide additional support for multiple installation orientations. Valve shall be self draining in any orientation.

JORLON DIAPHRAGM SEAL (3" ANGLE STYLE)

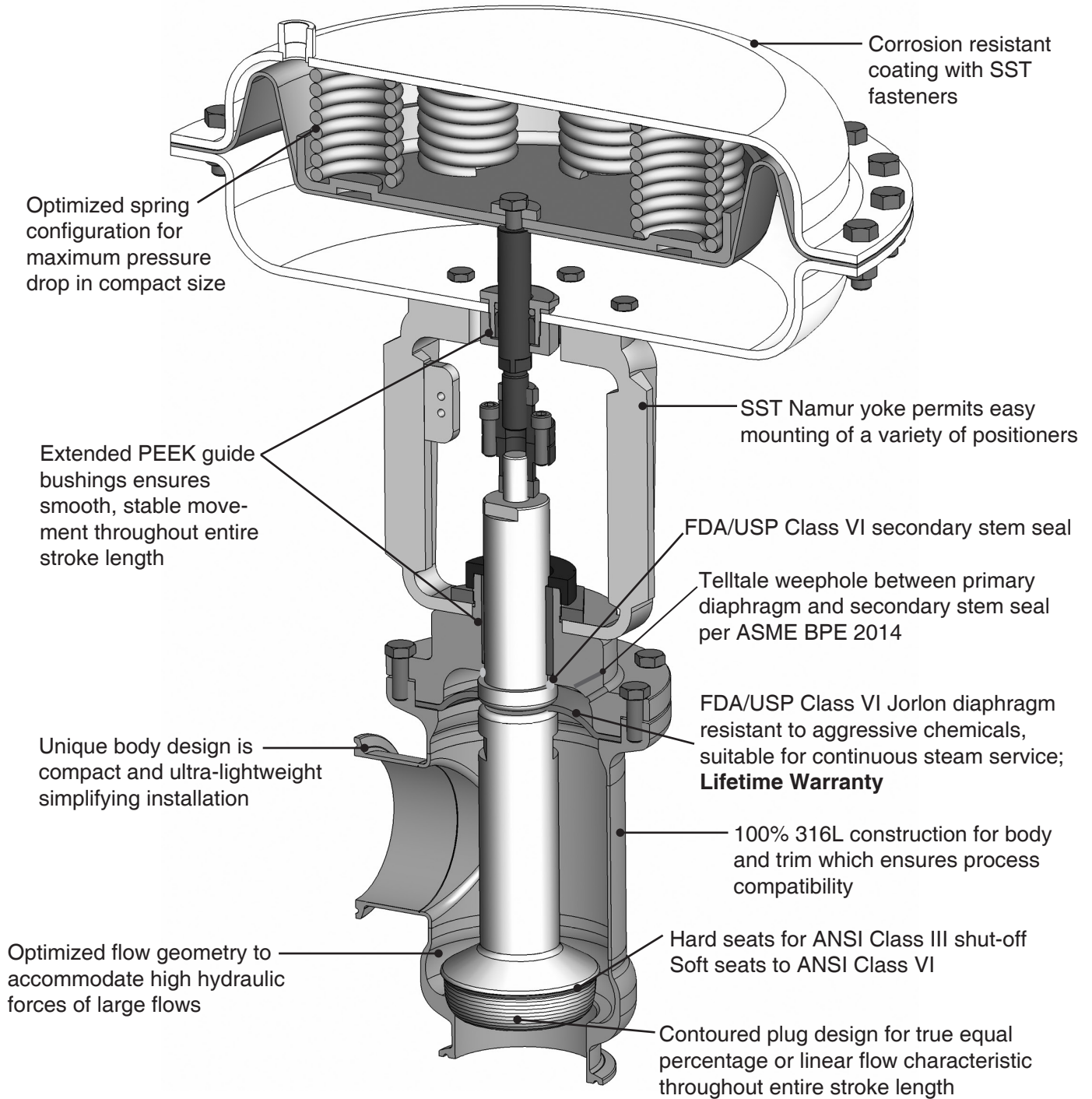

SPECIFICATION

Stainless steel sanitary control valve shall be made from ASTM SA479 316L material, which includes body and all wetted metal parts. Control valve with the stem sealed by FDA approved and USP Class VI certified Jorlon diaphragm with lifetime warranty. The valve stem shall be supported by a one piece, SS NAMUR Yoke to provide structural rigidity in any installation orientation. Guiding of valve stem/plug shall be outside of the wetted process areas of valve above diaphragm. Control valve shall have secondary stem seal, and extended guide bushing to provide additional support for multiple installation orientations. Valve shall be self draining when installed with inlet vertical and below valve assembly.

MARK 978E INLINE (1")

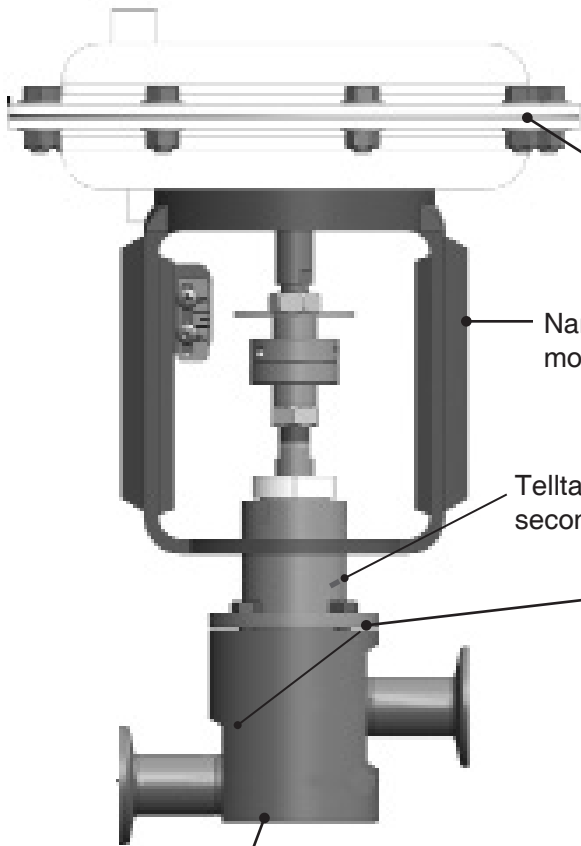

Corrosion resistant coating with SST fasteners

Namur yoke permits easy mounting of positioners

Telltale weep hole between primary diaphragm and secondary stem seal per ASME BPE 2014

Unique body design is compact and ultra-light-weight simplifying installation

100% 316L construction for body and trim which ensures process compatibility

New INLINE design allows process design flexibility. Process designers are no longer constrained by angle valve process tubing. Fully drainable, no hold up when installed as shown

MARK 978 INLINE (1-1/2" - 2")

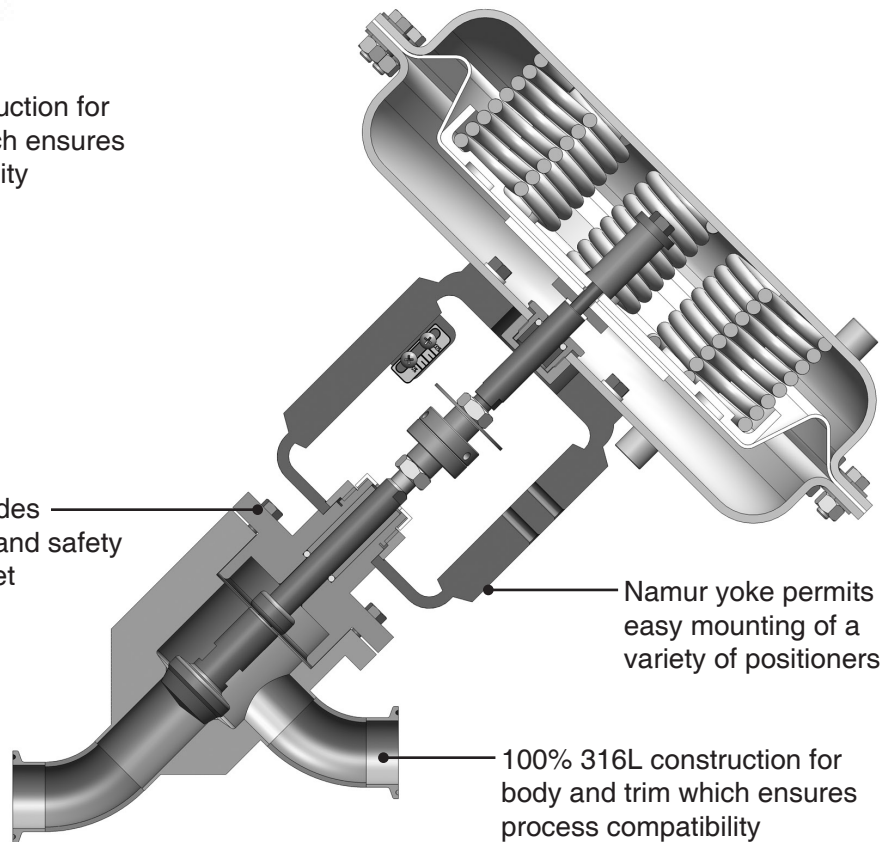

Bolted bonnet provides enhanced strength and safety over clamped bonnet

Namur yoke permits easy mounting of a variety of positioners

100% 316L construction for body and trim which ensures process compatibility

FDA/USP Class VI Jorlon diaphragm – resistant to aggressive process utilities, suitable for continuous steam service, **Lifetime Warranty**

DIMENSIONS

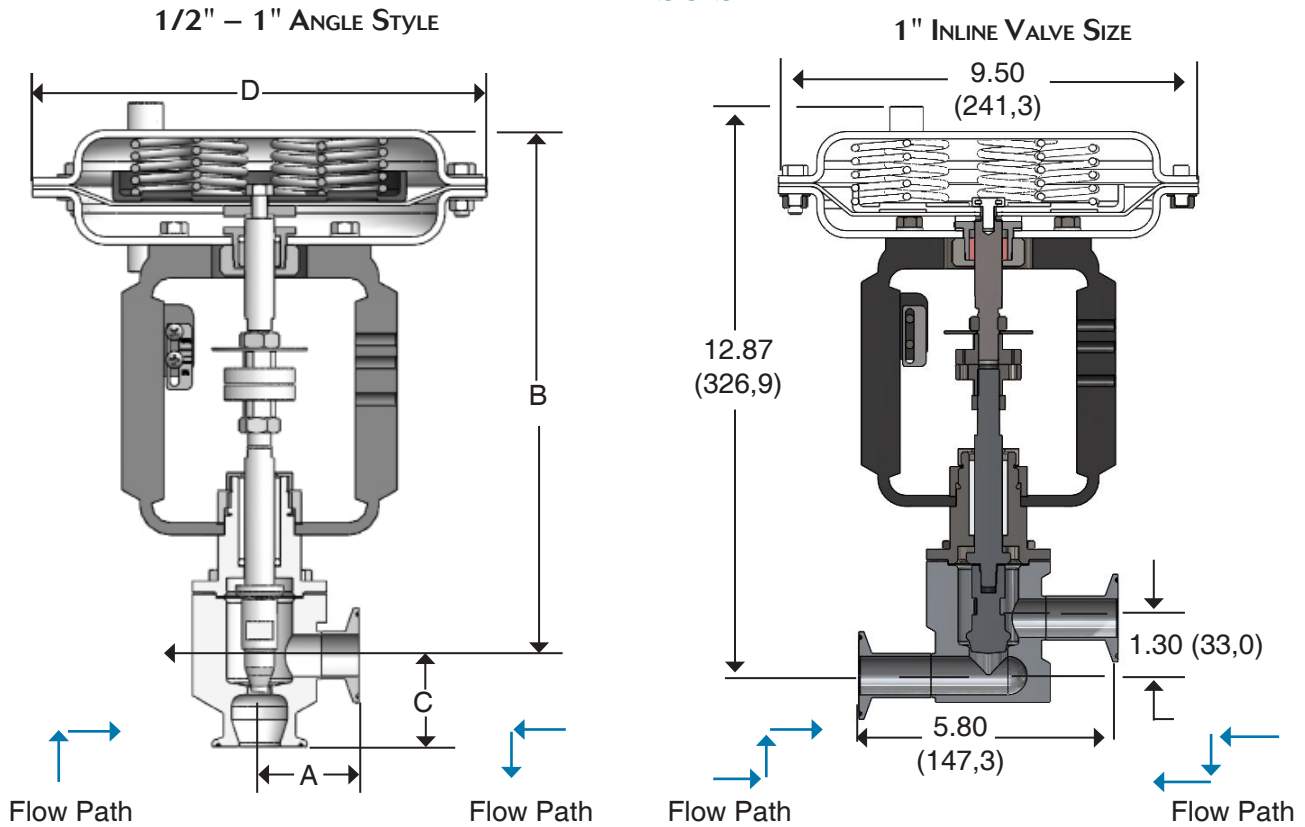

Installation and Drainability (for both valves):

- Valve can be installed with flow direction as shown above, or reverse
- For gravity drainage from inlet through outlet and no hold up when open, install upright as show above with flow entering the right side.

IMPORTANT:

The 1/2" - 1" MK978E can only be installed as shown above. If installed on it's side (90° from above orientation), it will not gravity drain.

- If you need to install a valve on it's side, order the MK978 (not the MK 978E). Call Steriflow or your Steriflow Representative for the MK978 data sheet, or for model number help.

DIMENSIONS 1/2" - 1" ANGLE STYLE

INCHES

Valve Size	Dimensions				Weight Lbs
	A	B	C	D	
1/2"	2.08	11.94	1.91	9.50 (35M)	27 (35M)
				12.50 (55M)	42 (55M)
3/4"	2.08	11.94	1.91	9.50 (35M)	27 (35M)
				12.50 (55M)	42 (55M)
1"	2.08	11.94	1.91	9.50 (35M)	27 (35M)
				12.50 (55M)	42 (55M)

METRIC

Valve Size	Dimensions				Weight Kgs
	A	B	C	D	
DN15	53	303	49	241 (35M)	12 (35M)
				318 (55M)	19 (55M)
DN20	53	303	49	241 (35M)	12 (35M)
				318 (55M)	19 (55M)
DN25	53	303	49	241 (35M)	12 (35M)
				318 (55M)	19 (55M)

Based on US tri-clamp ends. Consult factory for DIN and ISO tri-clamp end dimensions

DIMENSIONS

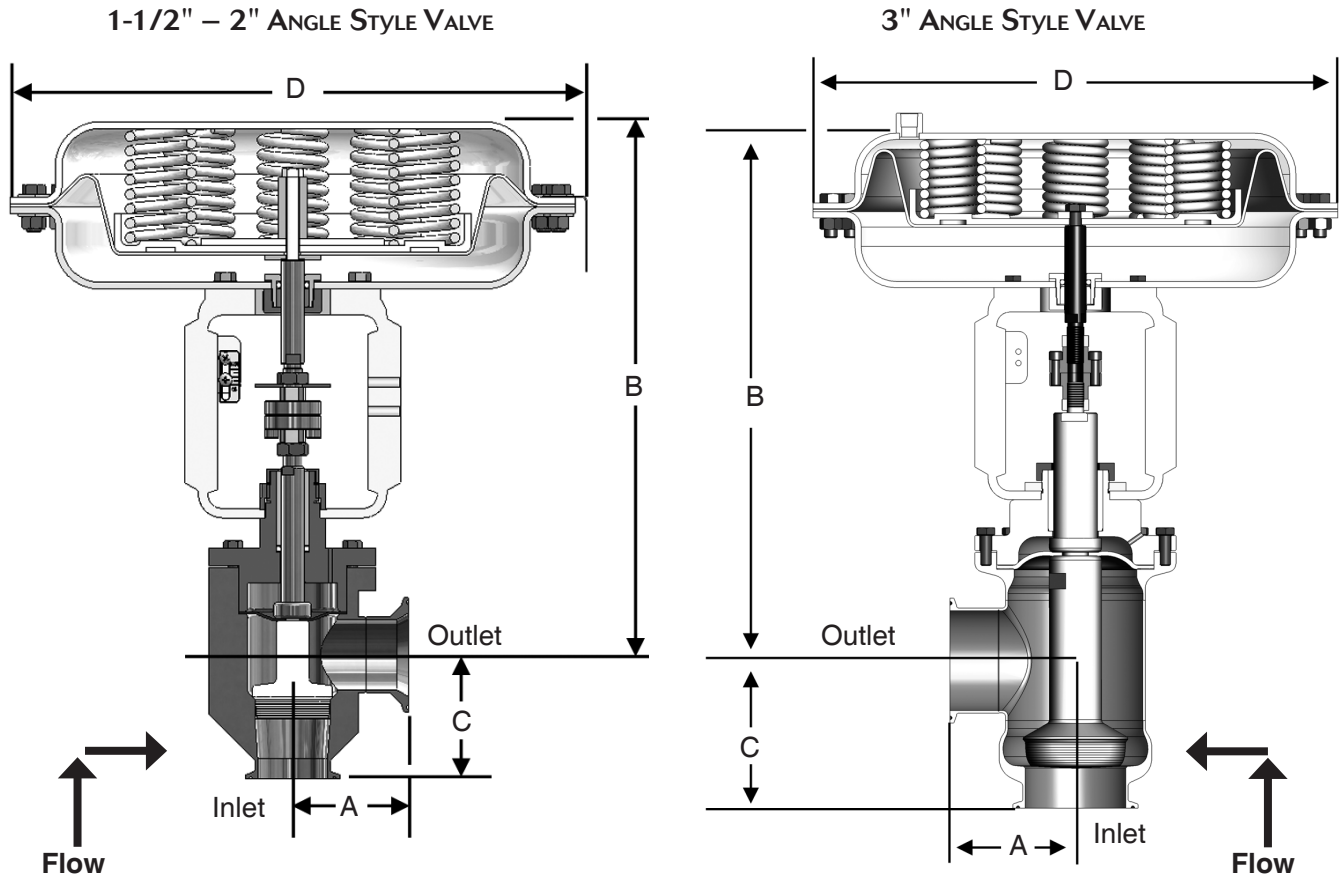

Installation Orientation and Drainability:

- Valve has no hold-up when installed as shown above, but must be drained below inlet.
- 1-1/2" - 2" valves will gravity drain from inlet to outlet, when installed with inlet horizontal (outlet facing down)
- 3" valve can only be installed as shown. It will not gravity-drain if installed on its side with outlet facing down.

INCHES

Valve Size	Dimensions				Weight Lbs
	A	B	C	D	
1-1/2"	3.08	15.00	3.30	12.50 (55M)	47 (55M)
				15.00 (85M)	57 (85M)
2"	3.08	15.00	3.30	12.50 (55M)	47 (55M)
				15.00 (85M)	57 (85M)
3"	3.59	15.1	4.2	15.00 (85M)	59 (85M)

METRIC

Valve Size	Dimensions				Weight Kgs
	A	B	C	D	
DN40	78	381	84	318 (55M)	21 (55M)
				381 (85M)	26 (85M)
DN50	78	381	84	318 (55M)	21 (55M)
				381 (85M)	26 (85M)
DN80	91	384	107	381 (85M)	27 (85M)

Based on US tri-clamp ends. Consult factory for DIN and ISO tri-clamp end dimensions

INLINE DIMENSIONS

1-1/2" & 2" INLINE VALVE

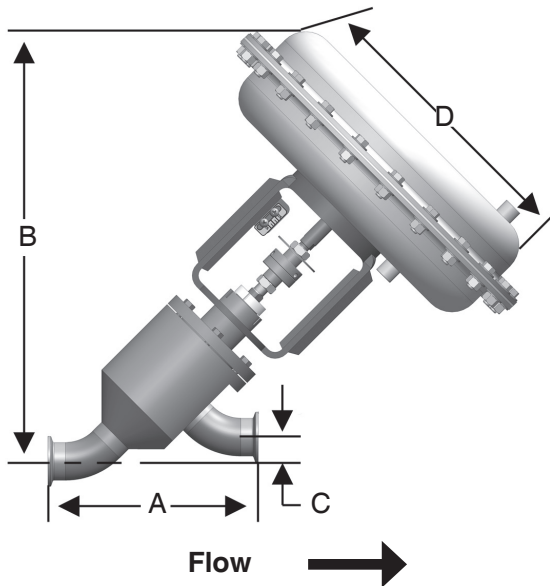

INCHES

Valve Size	Dimensions				Weight Lbs
	A	B	C	D	
1-1/2"	8.31	17.00	0.96	12.50 (55M)	49 (55M)
				15.00 (85M)	59 (85M)
2"	10.23	17.25	0.96	12.50 (55M)	49 (55M)
				15.00 (85M)	59 (85M)

METRIC

Valve Size	Dimensions				Weight Kgs
	A	B	C	D	
DN40	211	432	24,4	318 (55M)	22 (55M)
				381 (85M)	27 (85M)
DN50	260	438	24,4	318 (55M)	22 (55M)
				381 (85M)	27 (85M)

Based on US tri-clamp ends. Consult factory for DIN and ISO tri-clamp end dimensions

Installation Orientation and Drainability:

- Valve has no hold-up when installed as shown above, but must be drained below inlet.

NEW MK978 CONTROL VALVE OPTION: MOUNTING BRACKET

We now have a Stainless Steel Bracket Kit for all of our 1/2" – 2" MK978JD and OR angle style, and 1" Inline style Control Valves.

- The bracket (shown to the right) mounts to the base of the Namur Yoke and provides exceptional support for mounting to a pipe stand (Hardware included), wall or panel.
- Specifications:**
 - Materials:**
 - Bracket, HHCS: 316SS
 - Ubolts, Nut (for mounting to pipe stand): 304SS
 - Washers: 18/8 SS
 - Surface Finish:** 316SS Angle Standard Material Finish
- See the bottom of the MK978 pricing pages in the Steriflow Valve Price List for Kit 978-BRKT-KIT Pricing.

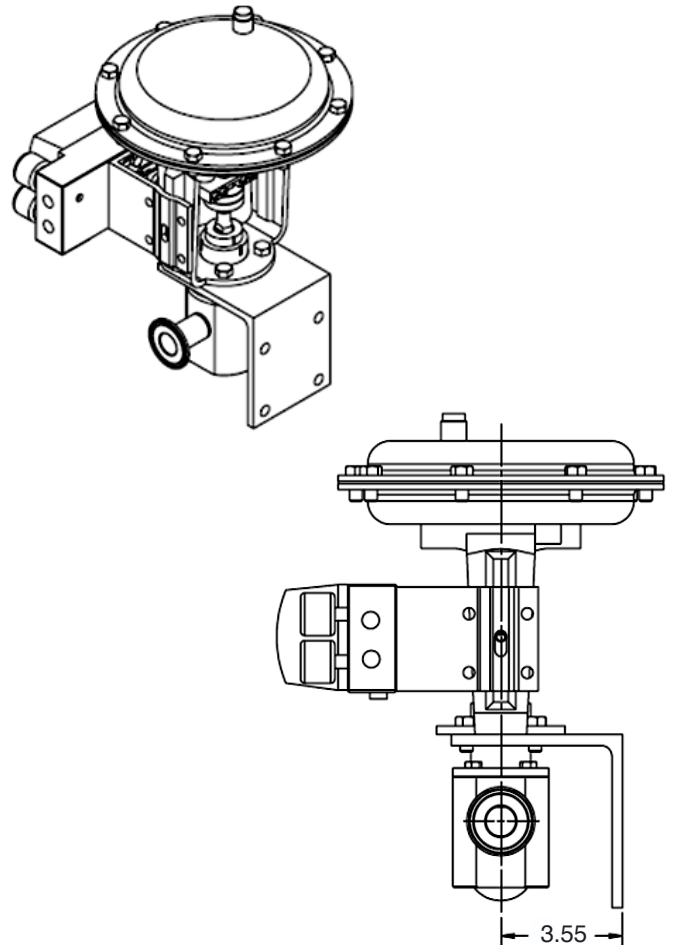

Kit Model Number: 978-BRKT-KIT

NOTE: the 1/2' - 1" MK978E can only be installed as shown on page 7.

IMPORTANT:

When ordering a replacement valve for an existing 1/2" - 1" MK978 or an identical model for a new process, the original valves serial number is required. Call Steriflow or your Steriflow Representative for assistance in specifying the MK978 (not the MK978E).

ORDERING SCHEMATIC (MK978E 1/2" – 1")

Model No	Size	Stem Seal / Seat	1	2	3	4	5	6	7	8	9	10	11	12	13	14	15

	Model
978E	Standard
978ESP	Side Mounted Positioner (SMP)
978ETP	Top Mounted Positioner (TMP)
978EN	In Line Body*
978ENSP	InLine with SMP*
978ENTP	InLine with TMP*

* Available for all Cv's in 1" only. Contact factory for others.

	Size
Ø50	1/2"
Ø75	3/4"
100	1"

	Stem Seal / Seat
JD	Jorlon Diaphragm / Hard Seat
JDP	Jorlon / PEEK (FDA/USP Class VI) (Cv ≥ 3.5 only)
JDT	Jorlon / Teflon FDA/USP Class VI (Cv ≥ 3.5 only)

1,2,3,4,5,6	1/2" Tri-C Body, Cv, Char. Finish
AALN1A	1/2" LIN Cv 0.2 20Ra int./63 RMS. ext.
A1LN1A	1/2" LIN Cv 0.2 20Ra int./20Ra ext.
A2LN1Ø	1/2" LIN Cv 0.2 8Ra int. /20Ra ext.
A3LN1Ø	1/2" LIN Cv 0.2 8Ra int./8Ra ext.
A4LN1Ø	1/2" LIN Cv 0.2 8Ra int./63RMS ext.
AAEPA1	1/2" EQP Cv 0.2 20Ra int./63 RMS ext.
A1EPA1	1/2" EQP Cv 0.2 20Ra int./20Ra ext.
A2EP11	1/2" EQP Cv 0.2 8Ra int./20Ra ext.
A3EP11	1/2" EQP Cv 0.2 8Ra int./8Ra ext.
A4EP11	1/2" EQP Cv 0.2 8Ra int./63 RMS ext.
AALN2A	1/2" LIN Cv 0.5 20Ra int./63RMS ext.
A1LN2A	1/2" LIN Cv 0.5 20Ra int./20Ra ext.
A2LN21	1/2" LIN Cv 0.5 8Ra int./20Ra ext.
A3LN21	1/2" LIN Cv 0.5 8Ra int./8Ra ext.
A4LN21	1/2" LIN Cv 0.5 8Ra int./63 RMS ext.
AAEPA2	1/2" EQP Cv 0.5 20Ra int./63 RMS ext.
A1EPA2	1/2" EQP Cv 0.5 20Ra int./20Ra ext.
A2EP12	1/2" EQP Cv 0.5 8Ra int./20Ra ext.
A3EP12	1/2" EQP Cv 0.5 8Ra int./8Ra ext.
A4EP12	1/2" EQP Cv 0.5 8Ra int./63 RMS ext.

1,2,3,4,5,6	1/2" Tri-C Body, Cv, Char. Finish
AALN3A	1/2" LIN Cv 1.0 20Ra int./63 RMS ext.
A1LN3A	1/2" LIN Cv 1.0 20Ra int./20Ra ext.
A2LN31	1/2" LIN Cv 1.0 8Ra int./20Ra ext.
A3LN31	1/2" LIN Cv 1.0 8Ra int./8Ra ext.
A4LN31	1/2" LIN Cv 1.0 8Ra int./63 RMS ext.
AAEPA3	1/2" EQP Cv 1.0 20Ra int./63 RMS ext.
A1EPA3	1/2" EQP Cv 1.0 20Ra int./20Ra ext.
A2EP13	1/2" EQP Cv 1.0 8Ra int./20Ra ext.
A3EP13	1/2" EQP Cv 1.0 8Ra int./8Ra ext.
A4EP13	1/2" EQP Cv 1.0 8Ra int./63 RMS ext.

ORDERING SCHEMATIC CONTINUED (MK978E 1/2" – 1")

1,2,3,4,5,6	3/4" Tri-C Body, Cv, Char. Finish
BALN1A	3/4" LIN Cv 1.0 20Ra int./63 RMS ext.
B1LN1A	3/4" LIN Cv 1.0 20Ra int./20Ra ext.
B2LN1Ø	3/4" LIN Cv 1.0 8Ra int./20Ra ext.
B3LN1Ø	3/4" LIN Cv 1.0 8Ra int./8Ra ext.
B4LN1Ø	3/4" LIN Cv 1.0 8Ra int./63 RMS ext.
BAEPA1	3/4" EQP Cv 1.0 20Ra int./63 RMS ext.
B1EPA1	3/4" EQP Cv 1.0 20Ra int./20Ra ext.
B2EP11	3/4" EQP Cv 1.0 8Ra int./20Ra ext.
B3EP11	3/4" EQP Cv 1.0 8Ra int./8Ra ext.
B4EP11	3/4" EQP Cv 1.0 8Ra int./63 RMS ext.
BALN2A	3/4" LIN Cv 2.0 20Ra int./63 RMS ext.
B1LN2A	3/4" LIN Cv 2.0 20Ra int./20Ra ext.
B2LN21	3/4" LIN Cv 2.0 8Ra int./20Ra ext.
B3LN21	3/4" LIN Cv 2.0 8Ra int./8Ra ext.
B4LN21	3/4" LIN Cv 2.0 8Ra int./63 RMS ext.
B2LNBC	3/4" LIN Cv 2.0 8Ra int/20Ra ext. - TBL
BAEPA2	3/4" EQP Cv 2.0 20Ra int./63 RMS ext.
B1EPA2	3/4" EQP Cv 2.0 20Ra int./20Ra ext.
B2EP12	3/4" EQP Cv 2.0 8Ra int./20Ra ext.
B3EP12	3/4" EQP Cv 2.0 8Ra int./8Ra ext.
B4EP12	3/4" EQP Cv 2.0 8Ra int./63 RMS ext.
CALN3A	3/4" LIN Cv 3.5 20Ra int./63 RMS ext.
C1LN3A	3/4" LIN Cv 3.5 20Ra int./20Ra ext.
C2LN31	3/4" LIN Cv 3.5 8Ra int./20Ra ext.
C3LN31	3/4" LIN Cv 3.5 8Ra int./8Ra ext.
C4LN31	3/4" LIN Cv 3.5 8Ra int./63 RMS ext.
CAEPA3	3/4" EQP Cv 3.5 20Ra int./63 RMS ext.
C1EPA3	3/4" EQP Cv 3.5 20Ra int./20Ra ext.
C2EP13	3/4" EQP Cv 3.5 8Ra int./20Ra ext.
C3EP13	3/4" EQP Cv 3.5 8Ra int./8Ra ext.
C4EP13	3/4" EQP Cv 3.5 8Ra int./63 RMS ext.
1,2,3,4,5,6	3/4" Tri-C Body, Cv, Char. Finish
CALN4A	3/4" LIN Cv 5.0 20Ra int./63 RMS ext.
C1LN4A	3/4" LIN Cv 5.0 20Ra int./20Ra ext.
C2LN41	3/4" LIN Cv 5.0 8Ra int./20Ra ext.
C3LN41	3/4" LIN Cv 5.0 8Ra int./8Ra ext.
C4LN41	3/4" LIN Cv 5.0 8Ra int./63 RMS ext.
C2LNBD	3/4" LIN Cv 5.0 8Ra int./20Ra ext. - TBL
CAEPA4	3/4" EQP Cv 5.0 20Ra int./63 RMS ext.
C1EPA4	3/4" EQP Cv 5.0 20Ra int./20Ra ext.
C2EP14	3/4" EQP Cv 5.0 8Ra int./20Ra ext.
C3EP14	3/4" EQP Cv 5.0 8Ra int./8Ra ext.
C4EP14	3/4" EQP Cv 5.0 8Ra int./63 RMS ext.

1,2,3,4,5,6	1" Tri-C Body, Cv, Char. Finish
DALN1A	1" LIN Cv 3.5 20Ra int./63 RMS ext.
D1LN1A	1" LIN Cv 3.5 20Ra int./20Ra ext.
D2LN1Ø	1" LIN Cv 3.5 8Ra int./20Ra ext.
D3LN1Ø	1" LIN Cv 3.5 8Ra int./8Ra ext.
D4LN1Ø	1" LIN Cv 3.5 8Ra int./63 RMS ext.
DAEPA1	1" EQP Cv 3.5 20Ra int./63 RMS ext.
D1EPA1	1" EQP Cv 3.5 20Ra int./20Ra ext.
D2EP11	1" EQP Cv 3.5 8Ra int./20Ra ext.
D3EP11	1" EQP Cv 3.5 8Ra int./8Ra ext.
D4EP11	1" EQP Cv 3.5 8Ra int./63 RMS ext.
DALN2A	1" LIN Cv 5.0 20Ra int./63 RMS ext.
D1LN2A	1" LIN Cv 5.0 20Ra int./20Ra ext.
D2LN21	1" LIN Cv 5.0 8Ra int./20Ra ext.
D3LN21	1" LIN Cv 5.0 8Ra int./8Ra ext.
D4LN21	1" LIN Cv 5.0 8Ra int./63 RMS ext.
DAEPA2	1" EQP Cv 5.0 20Ra int./63 RMS ext.
D1EPA2	1" EQP Cv 5.0 20Ra int./20Ra ext.
D2EP12	1" EQP Cv 5.0 8Ra int./20Ra ext.
D3EP12	1" EQP Cv 5.0 8Ra int./8Ra ext.
D4EP12	1" EQP Cv 5.0 8Ra int./63 RMS ext.
EALN3A	1" LIN Cv 7.5 20Ra int./63 RMS ext.
E1LN3A	1" LIN Cv 7.5 20Ra int./20Ra ext.
E2LN31	1" LIN Cv 7.5 8Ra int./20Ra ext.
E3LN31	1" LIN Cv 7.5 8Ra int./8Ra ext.
E4LN31	1" LIN Cv 7.5 8Ra int./63 RMS ext.
EAEPA3	1" EQP Cv 7.5 20Ra int./63 RMS ext.
E1EPA3	1" EQP Cv 7.5 20Ra int./20Ra ext.
E2EP13	1" EQP Cv 7.5 8Ra int./20Ra ext.
E3EP13	1" EQP Cv 7.5 8Ra int./8Ra ext.
E4EP13	1" EQP Cv 7.5 8Ra int./63 RMS ext.
1,2,3,4,5,6	1" Tri-C Body, Cv, Char. Finish
EALN4A	1" LIN Cv 15 20Ra int./63 RMS ext.
E1LN4A	1" LIN Cv 15 20Ra int./20Ra ext.
E2LN41	1" LIN Cv 15 8Ra int./20Ra ext.
E3LN41	1" LIN Cv 15 8Ra int./8Ra ext.
E4LN41	1" LIN Cv 15 8Ra int./63 RMS ext.
E2LNBD	1" LIN Cv 15 8Ra int./20Ra ext. - TBL
7 & 8	Stem Seal
JH	Jorlon / FDA / USP Class VI
ZZ	Non-Standard

ORDERING SCHEMATIC CONTINUED (MK978E 1/2" – 1")

9 & 10	Actuator / Range
	978 / 978TP/978N
3D	35M 3-15 DIR
3R	35M 3-15 REV
4D	35M 6-30 DIR
4R	35M 6-30 REV
5D	55M 3-15 DIR
5R	55M 3-15 REV
6D	55M 6-30 DIR
6R	55M 6-30 REV
	978SP
3D	35M ALL DIR
3R	35M ALL REV
5D	55M ALL DIR
5R	55M ALL REV

11 & 12	Action
DD	Direct
RR	Reverse

13 & 14	Accessories
∅∅	None
1A	I/P Trans. 4-20M / 3-15P
2A	Air Reg. with gage
3A	I/P Trans. 4-20M / 6-30P

15	SMP
N	None
A	SMP DIR / REV 3-15
B	SMP DIR / REV 3-9
C	SMP DIR / REV 9-15
D	SMP / IP DIR / REV 4-20
E	SMP / IP DIR / REV 4-12
F	SMP / IP DIR / REV 12-20
G	MK16IQ-S DIR / REV 4-20
H	MK16IQ - B DIR / REV 4-20
J	MK16IQ - FF DIR / REV 4-20

ORDERING SCHEMATIC (1-1/2" & 2")

Model No	Size	Stem Seal	Seat	1	2	3	4	5	6	7	8	9	10	11	12	13	14	15

Model	
978SP	Side Mounted Positioner
978TP	Top Mounted Positioner
978NSP	InLine with SMP
978NTP	InLine with TMP

Size	
150	1-1/2"
200	2"

Stem Seal	
JD	Jorlon Diaphragm

Seat	
	Leave blank for standard Hard Seat
P	PEEK (FDA/USP Class VI)
T	Teflon FDA/USP Class VI

1,2,3,4,5,6	1-1/2" Tri-C Body, Cv, Char. Finish
FALN1A	1-1/2" LIN Cv 5 20Ra int./63 RMS. ext.
F1LN1A	1-1/2" LIN Cv 5 20Ra int./20Ra ext.
F2LN1Ø	1-1/2" LIN Cv 5 8Ra int. /20Ra ext.
F3LN1Ø	1-1/2" LIN Cv 5 8Ra int./8Ra ext.
F4LN1Ø	1-1/2" LIN Cv 5 8Ra int./63RMS ext.
FAEPA1	1-1/2" EQP Cv 5 20Ra int./63 RMS ext.
F1EPA1	1-1/2" EQP Cv 5 20Ra int./20Ra ext.
F2EP11	1-1/2" EQP Cv 5 8Ra int./20Ra ext.
F3EP11	1-1/2" EQP Cv 5 8Ra int./8Ra ext.
F4EP11	1-1/2" EQP Cv 5 8Ra int./63 RMS ext.
FALN2A	1-1/2" LIN Cv 10 20Ra int./63 RMS. ext.
F1LN2A	1-1/2" LIN Cv 10 20Ra int./20Ra ext.
F2LN21	1-1/2" LIN Cv 10 8Ra int. /20Ra ext.
F3LN21	1-1/2" LIN Cv 10 8Ra int./8Ra ext.
F4LN21	1-1/2" LIN Cv 10 8Ra int./63RMS ext.
FAEPA2	1-1/2" EQP Cv 10 20Ra int./63 RMS. ext.
F1EPA2	1-1/2" EQP Cv 10 20Ra int./20Ra ext.
F2EP12	1-1/2" EQP Cv 10 8Ra int. /20Ra ext.
F3EP12	1-1/2" EQP Cv 10 8Ra int./8Ra ext.
F4EP12	1-1/2" EQP Cv 10 8Ra int./63RMS ext.

Continued on next column

1,2,3,4,5,6	1-1/2" Tri-C Body, Cv, Char. Finish
FALN3A	1-1/2" LIN Cv 15 20Ra int./63 RMS. ext.
F1LN3A	1-1/2" LIN Cv 15 20Ra int./20Ra ext.
F2LN31	1-1/2" LIN Cv 15 8Ra int. /20Ra ext.
F3LN31	1-1/2" LIN Cv 15 8Ra int./8Ra ext.
F4LN31	1-1/2" LIN Cv 15 8Ra int./63RMS ext.
FAEPA3	1-1/2" EQP Cv 15 20Ra int./63 RMS. ext.
F1EPA3	1-1/2" EQP Cv 15 20Ra int./20Ra ext.
F2EP13	1-1/2" EQP Cv 15 8Ra int. /20Ra ext.
F3EP13	1-1/2" EQP Cv 15 8Ra int./8Ra ext.
F4EP13	1-1/2" EQP Cv 15 8Ra int./63RMS ext.
GALN4A	1-1/2" LIN Cv 20 20Ra int./63 RMS. ext.
G1LN4A	1-1/2" LIN Cv 20 20Ra int./20Ra ext.
G2LN41	1-1/2" LIN Cv 20 8Ra int. /20Ra ext.
G3LN41	1-1/2" LIN Cv 20 8Ra int./8Ra ext.
G4LN41	1-1/2" LIN Cv 20 8Ra int./63RMS ext.
GAEPA4	1-1/2" EQP Cv 20 20Ra int./63 RMS ext.
G1EPA4	1-1/2" EQP Cv 20 20Ra int./20Ra ext.
G2EP14	1-1/2" EQP Cv 20 8Ra int./20Ra ext.
G3EP14	1-1/2" EQP Cv 20 8Ra int./8Ra ext.
G4EP14	1-1/2" EQP Cv 20 8Ra int./63 RMS ext.
GALN5A	1-1/2" LIN Cv 30 20Ra int./63 RMS. ext.
G1LN5A	1-1/2" LIN Cv 30 20Ra int./20Ra ext.
G2LN51	1-1/2" LIN Cv 30 8Ra int. /20Ra ext.
G3LN51	1-1/2" LIN Cv 30 8Ra int./8Ra ext.
G4LN51	1-1/2" LIN Cv 30 8Ra int./63RMS ext.
G2LNBB	1-1/2" LIN Cv 30 8Ra int./20Ra ext. - TBL

1,2,3,4,5,6	2" Tri-C Body, Cv, Char. Finish
HALN1A	2" LIN Cv 10 20Ra int./63 RMS. ext.
H1LN1A	2" LIN Cv 10 20Ra int./20Ra ext.
H2LN1Ø	2" LIN Cv 10 8Ra int. /20Ra ext.
H3LN1Ø	2" LIN Cv 10 8Ra int./8Ra ext.
H4LN1Ø	2" LIN Cv 10 8Ra int./63RMS ext.
HAEPA1	2" EQP Cv 10 20Ra int./63 RMS. ext.
H1EPA1	2" EQP Cv 10 20Ra int./20Ra ext.
H2EP11	2" EQP Cv 10 8Ra int. /20Ra ext.
H3EP11	2" EQP Cv 10 8Ra int./8Ra ext.
H4EP11	2" EQP Cv 10 8Ra int./63RMS ext.
HALN2A	2" LIN Cv 15 20Ra int./63 RMS. ext.
H1LN2A	2" LIN Cv 15 20Ra int./20Ra ext.
H2LN21	2" LIN Cv 15 8Ra int. /20Ra ext.
H3LN21	2" LIN Cv 15 8Ra int./8Ra ext.
H4LN21	2" LIN Cv 15 8Ra int./63RMS ext.

Continued on next page

ORDERING SCHEMATIC CONTINUED (1-1/2" & 2")

1,2,3,4,5,6	2" Tri-C Body, Cv, Char. Finish
HAEPA2	2" EQP Cv 15 20Ra int./63 RMS. ext.
H1EPA2	2" EQP Cv 15 20Ra int./20Ra ext.
H2EP12	2" EQP Cv 15 8Ra int. /20Ra ext.
H3EP12	2" EQP Cv 15 8Ra int./8Ra ext.
H4EP12	2" EQP Cv 15 8Ra int./63RMS ext.
HALN3A	2" LIN Cv 20 20Ra int./63 RMS. ext.
H1LN3A	2" LIN Cv 20 20Ra int./20Ra ext.
H2LN31	2" LIN Cv 20 8Ra int. /20Ra ext.
H3LN31	2" LIN Cv 20 8Ra int./8Ra ext.
H4LN31	2" LIN Cv 20 8Ra int./63RMS ext.
HAEPA3	2" EQP Cv 20 20Ra int./63 RMS. ext.
H1EPA3	2" EQP Cv 20 20Ra int./20Ra ext.
H2EP13	2" EQP Cv 20 8Ra int. /20Ra ext.
H3EP13	2" EQP Cv 20 8Ra int./8Ra ext.
H4EP13	2" EQP Cv 20 8Ra int./63RMS ext.
HALN4A	2" LIN Cv 30 20Ra int./63 RMS. ext.
H1LN4A	2" LIN Cv 30 20Ra int./20Ra ext.
H2LN41	2" LIN Cv 30 8Ra int. /20Ra ext.
H3LN41	2" LIN Cv 30 8Ra int./8Ra ext.
H4LN41	2" LIN Cv 30 8Ra int./63RMS ext.
HAEPA4	2" EQP Cv 30 20Ra int./63 RMS. ext.
H1EPA4	2" EQP Cv 30 20Ra int./20Ra ext.
H2EP14	2" EQP Cv 30 8Ra int. /20Ra ext.
H3EP14	2" EQP Cv 30 8Ra int./8Ra ext.
H4EP14	2" EQP Cv 30 8Ra int./63RMS ext.
IALN5A	2" LIN Cv 40 20Ra int./63 RMS. ext.
I1LN5A	2" LIN Cv 40 20Ra int./20Ra ext.
I2LN51	2" LIN Cv 40 8Ra int. /20Ra ext.
I3LN51	2" LIN Cv 40 8Ra int./8Ra ext.
I4LN51	2" LIN Cv 40 8Ra int./63RMS ext.
IALN6A	2" LIN Cv 60 20Ra int./63 RMS. ext.
I1LN6A	2" LIN Cv 60 20Ra int./20Ra ext.
I2LN61	2" LIN Cv 60 8Ra int. /20Ra ext.
I3LN61	2" LIN Cv 60 8Ra int./8Ra ext.
I4LN61	2" LIN Cv 60 8Ra int./63RMS ext.
JAML7A	2" MOD* LIN Cv 70 20Ra int./63 RMS. ext.
J1ML7A	2" MOD* LIN Cv 70 20Ra int./20Ra ext.
J2ML71	2" MOD* LIN Cv 70 8Ra int./20Ra ext.
J3ML71	2" MOD* LIN Cv 70 8Ra int./8Ra RMS. ext.
J4ML71	2" MOD* LIN Cv 70 8Ra int./63 RMS. ext.

* Modified Linear - contact factory for more information

9 & 10	Actuator / Range
	978 / 978TP/978N
5D	55M 3-15 DIR
5R	55M 3-15 REV
6D	55M 6-30 DIR
6R	55M 6-30 REV
8D	85M 3-15 DIR
8R	85M 3-15 REV
9D	85M 6-30 DIR
9R	85M 6-30 REV
	978SP
5D	55M ALL DIR
5R	55M ALL REV
8D	85M ALL DIR
8R	85M ALL REV

11 & 12	Action
DD	Direct
RR	Reverse

13 & 14	Accessories
00	None
1A	I/P Trans. 4-20M / 3-15P
2A	Air Reg. with gage
3A	I/P Trans. 4-20M / 6-30P

15	SMP
N	None
A	SMP DIR / REV 3-15
B	SMP DIR / REV 3-9
C	SMP DIR / REV 9-15
D	SMP / IP DIR / REV 4-20
E	SMP / IP DIR / REV 4-12
F	SMP / IP DIR / REV 12-20
G	MK16IQ-S DIR / REV 4-20
H	MK16IQ - B DIR / REV 4-20
J	MK16IQ - FF DIR / REV 4-20

7 & 8	Stem Seal
JH	Jorlon – FDA / USP Class VI

ORDERING SCHEMATIC (3")

Model No	Size	Stem Seal	Seat	1	2	3	4	5	6	7	8	9	10	11	12	13	14	15

Model	
978SP	Side Mounted Positioner

7 & 8	Stem Seal
JH	Jorlon - FDA/USP Class VI

Size	
300	3"

9 & 10	Actuator/Range
8D	85M Direct
8R	85M Reverse

Stem Seal	
JD	Jorlon Diaphragm

11 & 12	Action
DD	Direct
RR	Reverse

Seat	
	Leave blank for standard Hard Seat
P	PEEK (FDA/USP Class VI)
T	Teflon FDA/USP Class VI

13 & 14	Accessories
00	None
1A	I/P Trans. 4-20M / 3-15P
2A	Air Reg. with gage
3A	I/P Trans. 4-20M / 6-30P

1,2,3,4,5,6	3" Tri-C Body, Cv, Char. Finish
JALN1A	3" LIN Cv 75 20Ra int./63 RMS. ext.
J4LN10	3" LIN Cv 75 8Ra int./63RMS ext.
JAEP1A	3" EQP Cv 60 20Ra int. /63RMS ext.
J4EP11	3" EQP Cv 60 8Ra int./63RMS ext.
JALN2A	3" LIN Cv 100 20Ra 63RMS ext.
J4LN21	3" LIN Cv 100 8Ra int./63RMS ext.
JAEP2A	3" EQP Cv 80 20Ra int./63RMS ext.
J4EP12	3" EQP Cv 80 8Ra int./63RMS ext.
JAEP3A	3" EQP Cv90 20 Ra int./63RMS ext.
J4EP13	3" EQP Cv90 8Ra int/63RMS ext.

15	SMP
N	None
A	SMP DIR / REV 3-15
B	SMP DIR / REV 3-9
C	SMP DIR / REV 9-15
D	SMP / IP DIR / REV 4-20
E	SMP / IP DIR / REV 4-12
F	SMP / IP DIR / REV 12-20
G	MK16IQ-S DIR / REV 4-20 (HART®)
H	MK16IQ - B DIR / REV 4-20 (not HART®)
J	MK16IQ - FF DIR / REV 4-20 (Foundation Fieldbus™)

DOCUMENTATION

A Certificate of Compliance to material (with heat number and MTR's for body and ferule), surface finish and FDA USP Class VI is provided for each line item on all Steriflow orders at no charge. The following additional documentation is available from our factory upon request at time of ordering:

- Traceable Material Certificates for all wetted parts
- Final Test Reports
- Certificate of Compliance/Certificate of Origin



Steriflow, a division of Jordan Valve

3170 Wasson Road • Cincinnati, OH 45209
 513.533.5600 • 800.543.7311 • 513.871.0105 (f)
 steriflow@richardsind.com • www.steriflowvalve.com

Steriflow Valve reserves the right to make revisions to its product, specifications, literature and related information without notice. Please visit our website at www.steriflowvalve.com for the latest information on our products.